



Commercial Description

XL Static Duster

How to use

The anti dust cloth, thanks to its electrostatic power, attracts dust, crumbs, dirt, hair, avoiding their dispersion. To use both for dusting and both for any dust capture system for floor. To use dry without detergent. After use the surface will be perfumed and/or healthy. The increased size allows cleaning of large surfaces.

Technical Data

- Product quantity: - 16 wipes 22,5x45 cm
- Logistic: - 12 card boxes per carton
- packaging size 26x39x29,5 cm
- 54 box/pallet
- 648 pz/pallet

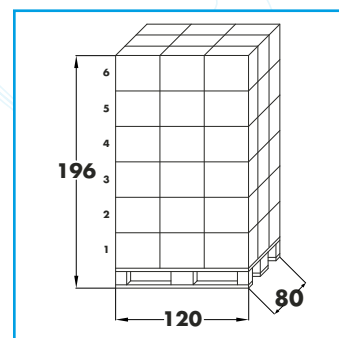

Variants

The wipe numbers per box and their size can vary. Consequently will change the technical data, product quantity and logistic.