



Commercial Description

Classical Anti Dust (capture dust)

How to use

The anti dust cloth, thanks to its electrostatic power, attracts dust, crumbs, dirt, hair, avoiding their dispersion. To use both for dusting and both for any dust capture system for floor. To use dry without detergent. After use the surface will be perfumed and/or healthy.

Technical Data

- Product quantity: - 20 wipes 22x28 cm
- Logistic: - 12 card boxes per carton
- packaging size 17x38x33 cm
- 84 box/pallet
- 1.008 pz/pallet

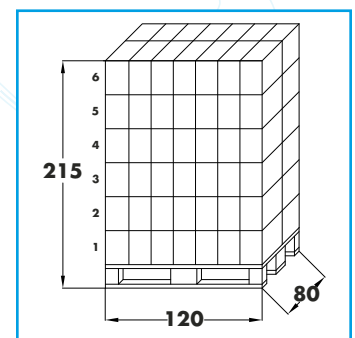

Variants

The wipe numbers per box and their size can vary. Consequently will change the technical data, product quantity and logistic.