



Commercial Description

Kit

How to use

Kit consisting of a telescopic handle in 4 pieces, base trapezoid with foam sponge and Puligenix fabric citrus scented. The article can be used to remove the dust and clean every kind of dirt, sanitize every kind of surface but also walls and ceilings. After use the surface, scented citrus, has not bacterial.

Technical Data

	- flow-pack 20 wipes 22x50 cm
Product quantity:	- 8 kit per outer box
	- packaging size 39x29x44 cm
Logistic:	- 32 box/pallet
	- 256 pz/pallet
	- packaging size 39x29x44 cm
	- 32 box/pallet
	- 256 pz/pallet

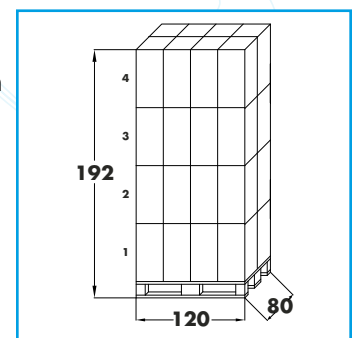

Variants

Possible to change the colour of the base and add a logo.

Possible to change the fragrance of the Puligenix wipes and possibly to add an antibacterial.