



Commercial Description

Colour Catcher "Classic"

How to use

The classic colour catcher, thanks to the exclusive patented technology, acts as a magnet: the special sheets absorb and trap the colours that disperse in water, avoiding that settle on garments. The proof is on the sheet, which after used is colored.

Technical Data

- Product quantity: - 20 sheets 22x12 cm
- Logistic: - 20 card boxes per carton
- packaging size 40x30x14 cm
- 128 box/pallet
- 2.560 pz/pallet

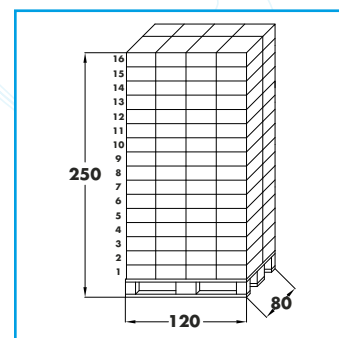

Variants

The size and the number of sheets per box may be changed at will. Consequently will change technical data, quantity and logistics.