



Commercial Description

Colour Catcher Anti Bacterial

How to use

The classic colour catcher, thanks to the exclusive patented technology, acts as a magnet: the special sheets absorb and trap the colours that disperse in water, avoiding that settle on garments. The proof is on the sheet, which after used is colored.

The innovative function added allows to reset the bacterial found also on clothes normally washed.

Technical Data

- Product quantity: - 20 sheets 22x12 cm
- Logistic: - 20 card boxes per carton
- packaging size 40x30x14 cm
- 128 box/pallet
- 2.560 pz/pallet

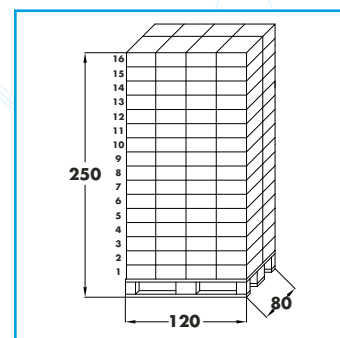

Variants

The size and the number of sheets per box may be changed at will. Consequently will change technical data, quantity and logistics.