



Commercial Description Colour Catcher for Wool

How to use

The colour catcher for wool, thanks to the exclusive patented technology, acts as a magnet: the special wipes absorb and trap the dissolved colours, avoiding that settle on garments. Their best performances on wool garments (accreditation by Woolmark as the only and the best colour catcher for wool).

Technical Data

- Product quantity: - 20 sheets 22x12 cm
- Logistic: - 20 card boxes per carton
- packaging size 40x30x14 cm
- 128 box/pallet
- 2.560 pz/pallet

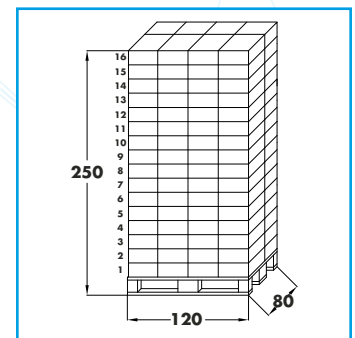

Variants

The size and the number of sheets per box may be changed at will. Consequently will change technical data, quantity and logistics.